



A Canadian Solar subsidiary



T4 PV CONNECTOR
INSTALLATION MANUAL

For professional use only

1.	T4 CONNECTOR PARTS	3
2.	T4 PRODUCT SPECIFICATIONS	3
3.	T4 CONNECTOR TYPE	4
4.	SAFETY PRECAUTIONS	4
5.	T4 FIELD TOOLKIT	4
6.	CONNECTOR & WIRE ASSEMBLY STEPS	5
7.	THE CORRECT CONNECTION	7
8.	DISCONNECTING THE CONNECTORS	7
	AMENDED EDITIONS AND DATES	7
	LIST OF FORBIDDEN CHEMICAL SUBSTANCES	8

1. T4 CONNECTOR PARTS

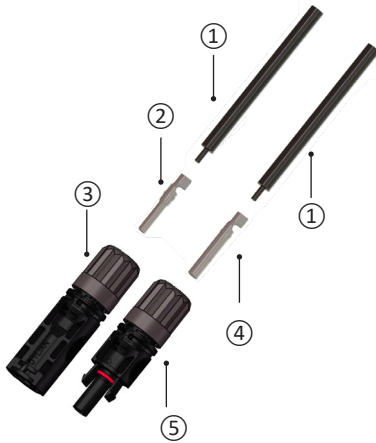

Item	Part Name
1	PV Cable
2	Male Pin Contact (-)
3	Male Connector (-)
4	Female Socket Contact (+)
5	Female Connector (+)

2. T4 CONNECTOR SPECIFICATIONS

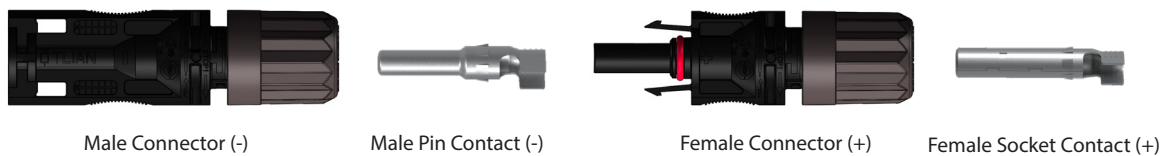





ELECTRICAL DATA:

Connector Specification	T4-PC-1
Rated Voltage	IEC 1500 V DC & UL 1500 V DC
Rated Current	32 A for 4 mm ² / 12 AWG 32 A for 6 mm ² / 10 AWG
Contact Resistance	≤ 0.25 mΩ
Pollution Degree	Class II
Protection Class	Class II
Protection Degree	IP68
Fire Resistance	UL 94-V0
Temperature Range	- 40 °C ~ + 90 °C
Rated Impulse Voltage	16 kV

MECHANICAL DATA:

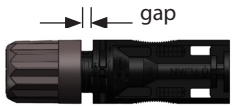
Connector Specification	T4-PC-1
Cable Range	IEC: 4 mm ² / 6 mm ² UL: 12 AWG / 10 AWG
Connector System	Φ 4.0 mm
Contact Material	Copper, Tin-plated
Type of Termination	Crimping

3. T4 CONNECTOR TYPE

Article	Cable Outside Diameter (OD)	Picture	Required Torque to Lock	Reference Gap
Male Connector (-)	4.3mm - 6.9mm		3.0 N·m ~ 4 N·m	0.5 < gap ≤ 1.5mm
Female Connector (+)				
Male Pin Contact (-)	---		---	---
Female Socket Contact (+)	---		---	---

4. SAFETY PRECAUTIONS

Products must be assembled and installed by qualified personnel, ensuring all safety regulations are followed. For protection against electric shock, please ensure the system is not energized during installation. Do not disconnect under load. Ensure that the AC and the DC sides are both disconnected and the system is not energized before disconnecting.

Use only the tools and components listed in this installation manual. Follow the instructions as stated in this manual. Do not alter or willingly damage the product in anyway.

- Sealing cap must be used on disconnected connectors to prevent dust ingress.
- Connectors are IP68-rated when mated.
- Do not place connector directly on roof surface.
- **CAUTION** : The exposure to or direct contact with chemicals or oils of T4 product may cause corrosion, degradation of performance, or cracking of the product, thus such exposure or direct contact should be strictly prohibited during the process of product manufacturing, transportation, installation and application.

It is the user's responsibility to validate any chemical that may come into contact with or used in any of the processes mentioned above, to ensure that such chemical will not affect the performance of T4 products.

5. T4 FIELD TOOLKIT

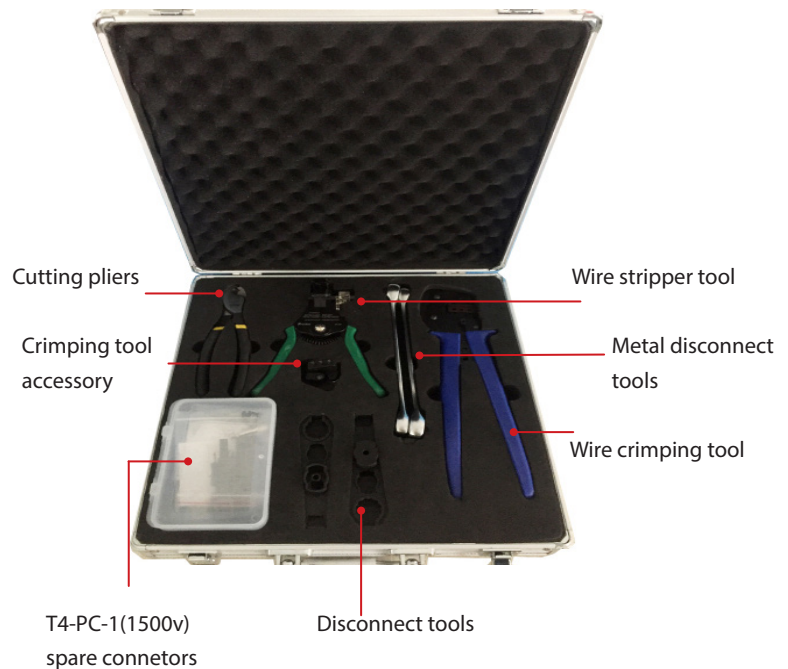

PARTS INCLUDED IN FIELD TOOLKIT:

Wire stripper tool

Type	Crimping Range	
2.5/14	2.5 mm ²	14 AWG
4.0/12	4.0 mm ²	12 AWG
6.0/10	6.0 mm ²	10 AWG

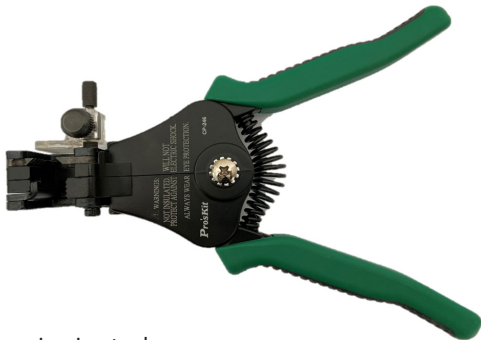

Wire crimping tool

Mark	Riveting Range	
2.5/14	2.5 mm ²	14 AWG
4.0/12	4.0 mm ²	12 AWG
6.0/10	6.0 mm ²	10 AWG



Crimping tool accessory - part of wire crimping tool



Cutting pliers



Disconnect tools

1 set = 2 pieces



6. CONNECTOR & WIRE ASSEMBLY STEPS

STEP 1:

VISUAL INSPECTION OF CONNECTOR

FEMALE CONNECTOR

- a. Sealing ring should fit cleanly in the slot and not be warped or distorted.

Sealing ring



- b. The two plastic clasps should be intact.
- c. Female connectors should not be obstructed by foreign objects or water.
- d. Plastic components should not be cracked.
- e. No damage should be visible on the cable.

MALE CONNECTOR

- a. Male connector should not be obstructed by foreign objects or water.
- b. Plastic components should not be cracked.
- c. No damage should be visible on the cable.



STEP 2:
STRIP THE INSULATION OFF THE CABLE

Using the wire stripper tool, remove the insulation from the cable. Ensure that 7.5 mm of cable are exposed, and that the wire strands are not damaged during the process of stripping the insulation.

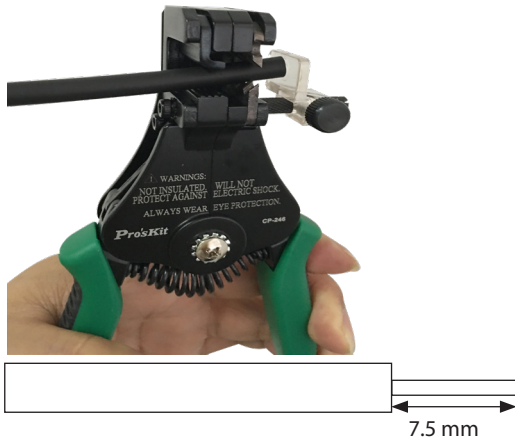

STEP 3:
CRIMP THE CONTACT

Place the contact around the bare section of the stripped wire. Crimp the contact using the wire crimping tool. The crimped contact should withstand pull forces of ≥ 310 N.



STEP 4:
INSERT THE CONTACT

Push the crimped contact back into the connector until you hear a click. Lightly pull the wire to ensure the metal components of the connector are engaged.

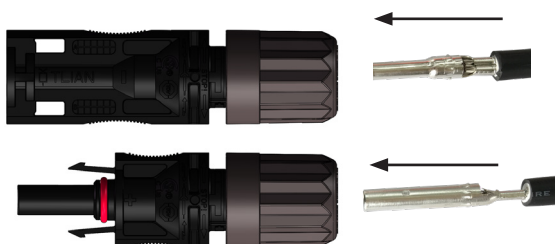

STEP 5:
TIGHTEN THE CABLE GLAND

First, tighten the gland by hand, then use the disconnect tools to tighten the gland to the connector until it clicks, ensuring that it is locked. When tightening the male connector, please use aligner available on the disconnect tool in order to ensure the pin is not skewed.



STEP 6:
MAKE CONNECTION

Check the appearance of the connectors before connecting them together. The sealing ring should be in the slot with no warping or distortion. The plastic clasps should not be damaged or broken. The connectors should be free of moisture and foreign objects. Plastic parts should not be cracked. Wire should not be frayed or damaged. When attaching, insert the connectors into each other until you hear a "click". Once attached, gently pull on the connectors to ensure they are firmly connected and cannot be easily disconnected by hand.

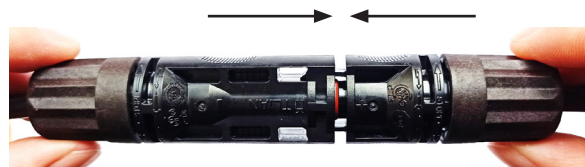

STEP 7:
VISUAL INSPECTION OF THE CONNECTION

To check the connection, ensure that you cannot see the sealing ring. The gap between the connectors should be less than 0.5 mm.

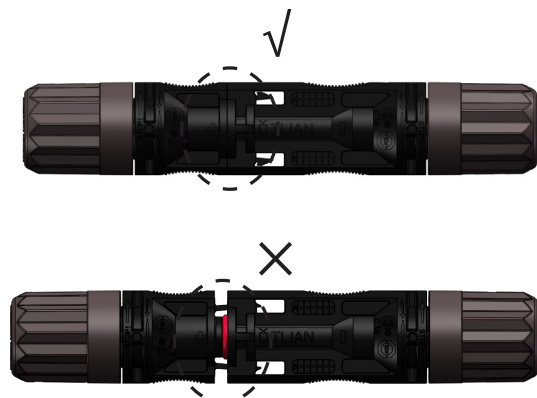

7. THE CORRECT CONNECTION

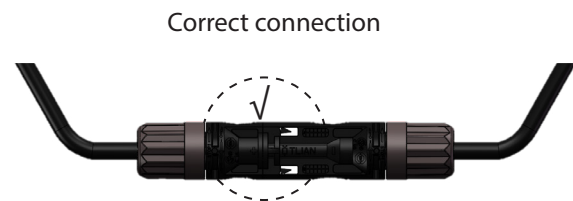
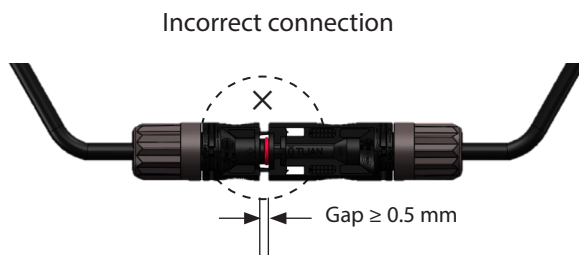
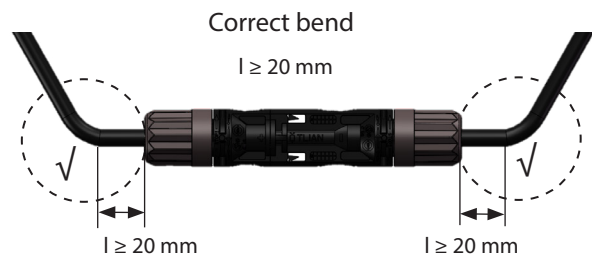
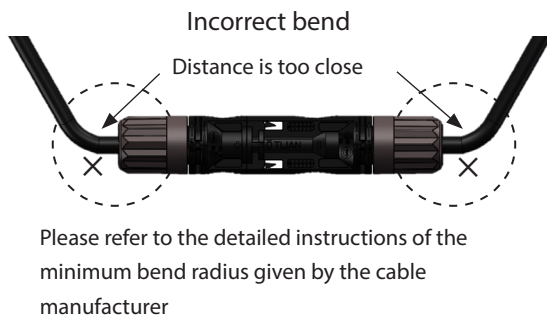

8. DISCONNECTING THE CONNECTORS

The mated connectors can only be disconnected by using the disconnect tools.

Insert the clasp of the disconnect tool in the slots of the male connector, and the female connector will automatically get disconnected.

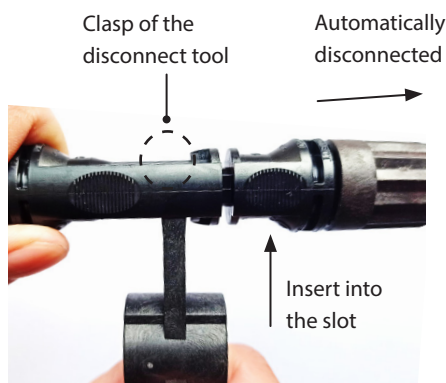

AMENDED EDITIONS AND DATES

Rev 1.0 was released in November 2016.
 Rev 1.1 was amended and released in May 2017.
 Rev 1.2 was amended and released in Sep 2017.
 Rev 1.3 was amended and released in Apr 2019.
 Rev 1.4 was amended and released in Sep 2019.
 Rev 1.5 was amended and released in Apr 2020.

The technical descriptions herein are only for reference when using these products.



WARNING

Users of T4 products should prevent the exposure of T4 products to any of the following chemical substances listed below. These chemicals may cause corrosion, degradation of performance, or cracking of product and might lead to potential safety issues in applications.

Lists of all known chemicals:

Class	Chemical Name
Commonly used chemicals	Food release spray ,Herbicide,Insecticide,Grease,Lubricate oil,Rust inhibitors ,REMA New punch oil,Stamping oil,Engine Oil,Banana Oil,WD-40,Oily sealing agent,Doduconta B25 Kontaktol,Evabrite S,Virex TB,Suma Lima L3,Suma Rinse,Detergent,Plasticizer,Spray cleaner 8188,CM-31S,REMA cleaner oil,DX-1,CH1160.
Disinfectants/Cleaners	Betadine,Cide,Ammonia,Organic Ammonium Chloride,Hydrogen peroxide,Bleach,Saline.
Oils	Die Cut(OELHELD) ,Machine Oil KV46(Nippon Oil),Infeld stamping oil.
Edible	Corn oil,Cola,Light syrup,Rapeseed oil,Blend oil,Olive oil, Castor oil,Soybean oil,Coconut oil.
Acid,Alkali,Salt	Ammonium hydrogen,Potassium hydroxide,Salt acid,Sulfuric acid,Nitric acid,Phosphoric acid,Acetic acid,Ammonia,Sodium hydroxide.
Grease	Vaseline ,Molykote EM-50L(Dow Corning),Molykote PG-641(Dow Corning).
Mould Release Agent	Pelicoat S-6(Chukyo-Kasei).
Binder	Chemlok(LORD).
Alcohols	Ethylene glycol,Amyl alcohol,Ethanol,Isopropanol,Isopropyl alcohol(IPA).
Fatty hydrocarbons	Heptane, Hexane, Cyclohexane, Liquid paraffin.
Halogenated hydrocarbon	Freon, Carbon tetrachloride, Trichloromethane, Virex 256.
Ketone	Methyl Ethyl Ketone (MEK), Acetone, Methyl ethyl ketone.
Aromatic Hydrocarbon	Toluene, Xylene, Cresol.
Other, Organic solvent	Oleic acid C18H34O2, Nonanal C9H18O, Oleic acid C9H18O2, Ethyl acetate, Butyl acetate, Tributyl phosphate, Kerosene, Gasoline, Varnish, Esters, Ethers, Amines, Glacial acetic acid, Print ink, 3M.
Adhesion sealant	APF125(Wacker Chemical) 3M adhesive,Avancis adhesive.
Potting Material	KE-200(ShinEtsu),CX-200(ShinEtsu).

Remarks:

For any chemical not listed above that may come into contact with any T4 product,it is the user's responsibility to validate that such chemical will not affect the performance of T4 products.

TLIAN (CHANGSHU) CO., LTD.
Guanghuahuan Road No.6, Changshu, China